



**QUICK-FIT**



**THE WORLD'S FASTEST DUCTING**

**END CAP**

Ø	PART NO.	ENDS	WEIGHT (GALV)
3"	3151-0300	QF	0.30
4"	3151-0400	QF	0.37
5"	3151-0500	QF	0.50
6"	3151-0600	QF	0.72
7"	3151-0700	QF	0.92
8"	3151-0800	QF	1.10
9"	3151-0900	QF	1.40
10"	3151-1000	QF	1.65
11"	3151-1100	QF	1.85
12"	3151-1200	QF	2.05
13"	3151-1300	QF	2.45
14"	3151-1400	QF	3.10
15"	3151-1500	QF	3.55
16"	3151-1600	QF	4.00
17"	3151-1700	QF	4.45
18"	3151-1800	QF	4.90
20"	3151-2000	QF	5.45
22"	3151-2200	QF	6.30
24"	3151-2400	QF	7.90



• End Caps enable users to close off taps for future use.



**END CAP WITH BIRD SCREEN**

Ø	PART NO.	ENDS	WEIGHT (GALV)
3"	3152-0300	QF	0.25
4"	3152-0400	QF	0.30
5"	3152-0500	QF	0.35
6"	3152-0600	QF	0.52
7"	3152-0700	QF	0.60
8"	3152-0800	QF	0.70
9"	3152-0900	QF	0.80
10"	3152-1000	QF	0.90
11"	3152-1100	QF	0.95
12"	3152-1200	QF	1.00
13"	3152-1300	QF	1.15
14"	3152-1400	QF	1.25
15"	3152-1500	QF	1.36
16"	3152-1600	QF	1.48
17"	3152-1700	QF	1.60
18"	3152-1800	QF	1.75
20"	3152-2000	QF	1.90
22"	3152-2200	QF	2.10
24"	3152-2400	QF	2.85

**End Cap With Bird Screen**



• End cap with birdscreen 1/2" galvanized wire mesh.

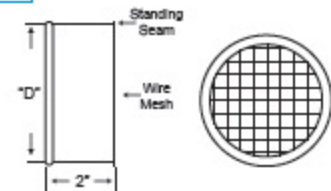

**REDUCER**

Ø	PART NO.	ENDS	GAUGE		WEIGHT (GALV)
			GAL.	SS	
3"	3222-03XX	QF	22	22	1.00
4"	3222-04XX	QF	22	22	1.25
5"	3222-05XX	QF	22	22	1.50
6"	3222-06XX	QF	22	22	1.75
7"	3222-07XX	QF	22	22	2.00
8"	3222-08XX	QF	22	22	2.25
9"	3222-09XX	QF	22	22	2.50
10"	3222-10XX	QF	22	22	3.00
11"	3222-11XX	QF	22	22	3.50
12"	3222-12XX	QF	22	22	3.75
13"	3222-13XX	QF	22	22	4.00
14"	3222-14XX	QF	22	22	4.50
15"	3222-15XX	QF	22	22	6.00
16"	3222-16XX	QF	20	20	7.00
17"	3222-17XX	QF	20	20	10.25
18"	3222-18XX	QF	20	20	21.00
20"	3222-20XX	QF	20	20	30.00
22"	3222-22XX	QF	20	20	39.50
24"	3222-24XX	QF	20	20	53.50
26"	3222-26XX	FLANGE	18	18	74.00
28"	3222-28XX	FLANGE	18	18	98.00
30"	3222-30XX	FLANGE	18	18	117.05
32"	3222-32XX	FLANGE	18	18	125.94
34"	3222-34XX	FLANGE	18	18	134.83
36"	3222-36XX	FLANGE	18	18	142.78
38"	3222-38XX	FLANGE	18	18	153.47
40"	3222-40XX	FLANGE	18	18	162.61

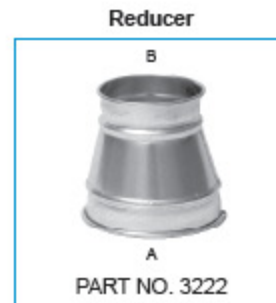

• Priced by large end 'A'.  
• When ordering specify A,B.  
• Specify reducer end style.  
"X" & "Y" are standard 1 3/4" long.  
QF length (L)= A-B+6", 7" min.  
FL length (L)= A-B+8", 9" min.

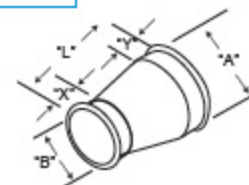

NOTE: See page 35 for ordering instructions

**ORDERING NOTES:**

Unless specified, 3" through 24" is QF, over 24" is flanged. Data is subject to change without notice. Stainless steel components requiring flanges will be supplied with SS flanges unless otherwise specified. Stainless steel components are manufactured with NO.304 SS. [Prices for SS 316 = SS 304 X 1.25] Adding a SS after standard part numbers specifies a SS part. For special parts or items to be custom manufactured call for quotation.

WWW.DUCTMONKEY.NET • 951-739-9593

**REDUCER STYLES**

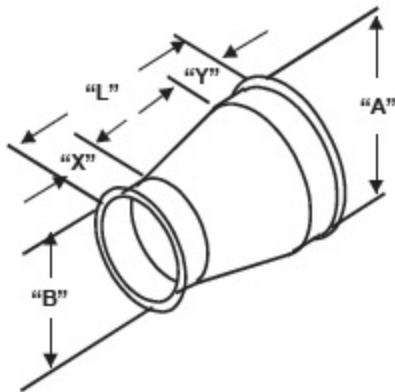

"Q-F STYLE"

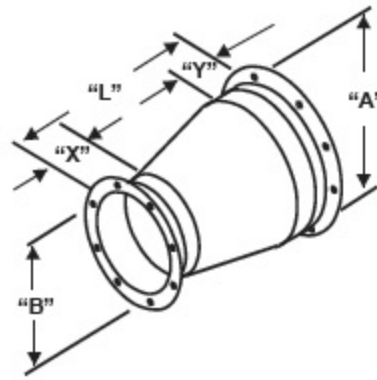

"FLANGED STYLE"

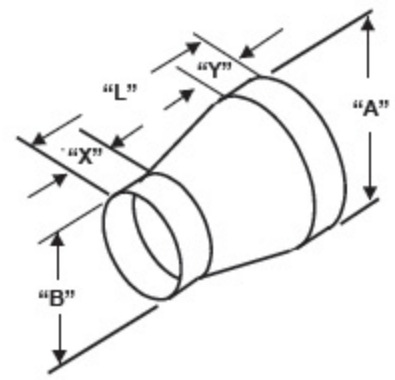

"RAW END STYLE"

A) Reducers are produced by the following formula:

"QF" LENGTH = (A-B) + 6" [7" MIN]  
 "FL" LENGTH = (A-B) + 8" [9" MIN]

B) Material gauges as follows:

DIA.	GALV. GAUGE	SS GAUGE
4" - 12"	22	22
14" - 22"	20	20
14" - 22"	18	18

NOTE: Any combination of the above style are available upon request. Please specify all the required dimensions and all reducer end configurations (Raw ID, Raw OD Style, QF Style, Flange Style, Etc.).

Item#	Qty	"A"	Style "Q-F" "Flange" "Raw"	"B"	Style "Q-F" "Flange" "Raw"	"L" (A-B+6)	"X" STD-2"	"Y" STD-2"	Part Gauge	Flange Material	Fig Dwg	Special Notes

**ORDERING NOTES:**

Unless specified, 3" through 24" is QF, over 24" is flanged. Data is subject to change without notice. Stainless steel components requiring flanges will be supplied with SS flanges unless otherwise specified. Stainless steel components are manufactured with NO.304 SS. [Prices for SS 316 = SS 304 X 1.25] Adding a SS after standard part numbers specifies a SS part. For special parts or items to be custom manufactured call for quotation.